

# MasterSheet

009 0002  
Revision 09/13/05



**BMW 318, 325**  
**1984-91 Coupe, Sedan**  
**1987-93 Convertible**

## IMPORTANT

Before starting, compare items on your invoice with items received. Carefully check through packaging material. If any item is missing, please call **Crutchfield Technical Service at 1-800-955-9094**.

Although reasonable attempts are made to verify the accuracy of the information contained in this MasterSheet, it is presented without warranties or guarantees of any type due to the constantly changing nature of this type of information and running changes in vehicle production. Any person or entity using this information does so at his or its own risk. If you find our instructions are different from your vehicle, or if you have questions, do not continue with your installation. Contact our toll-free technical support for assistance.



## Inside...

Page

2	Factory Radio Removal	✓						
3	Antenna Installation					✓	✓	
4	DIN Receiver Installation			✓				
5	Shaft Receiver Installation				✓			
6	Kick Panel Speakers		✓					
7	Rear Speakers (Sedan)		✓			✓		
8	Rear Speakers (Convertible)		✓			✓		
		5/64" Allen Wrench or BMW Radio Removal Tool	Phillips Screwdriver	Flat Blade Screwdriver	No Tools Required	Panel Tool	8mm Socket, Ratchet & Extension	Adjustable Wrench

## Tools Required ▶

**Note:** The BMW radio removal tool is available at BMW Dealerships.

# Factory Radio Removal

**Note:** *The factory radio is an anti-theft type. If you plan to reinstall it at a later date, make sure the code is available.*

1. Set parking brake and disconnect negative battery cable to prevent any electrical short.
2. Carefully pry open the **cover caps** on each side of the factory radio.
3. Using a BMW factory radio removal tool, (available at BMW dealerships) insert tool into opening on each side of radio. Turn to unlock mechanisms.
4. Pull radio out of dash. Disconnect wiring harnesses and unplug antenna lead. Remove radio.

**Note:** The end of the Allen wrench differs from the BMW tool. However, it does work if the proper size is used.

BMW Radio Removal Tool

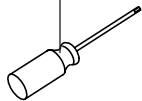

or



Allen Wrench

Cover Caps

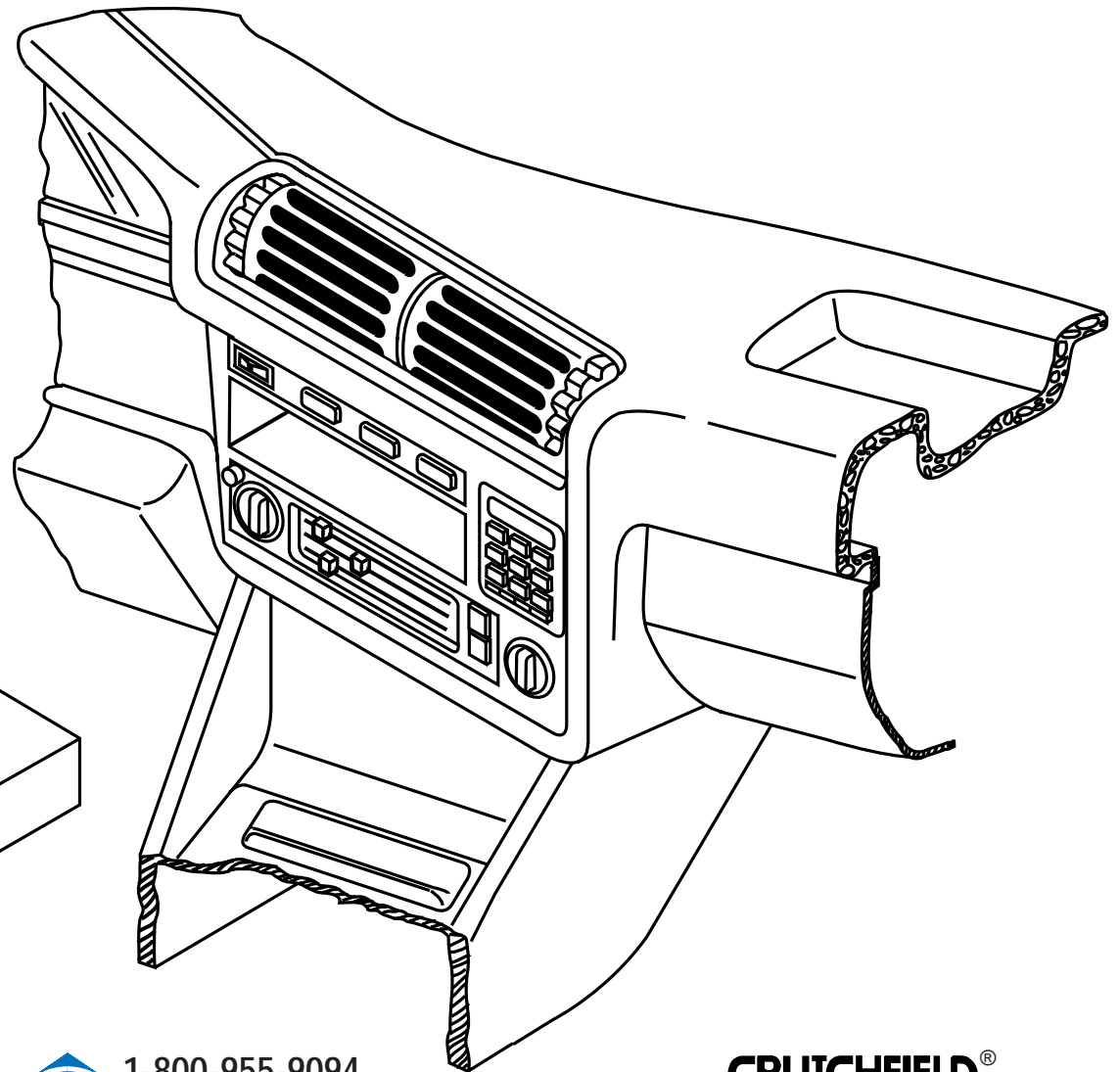

1-800-955-9094  
Technical Service

009 0002

# Antenna Replacement

1. Remove jack accessories and fold back **trunk liner** panel to access antenna.
2. Remove two (2) 8mm bolts from antenna lower support bracket.
3. Remove antenna retaining nut with an adjustable wrench and pull antenna out through bottom of fender. Remove and disconnect antenna.
4. Secure replacement antenna to fender as shown and make necessary connections according to instructions supplied with antenna.
5. Test for proper operation and reinstall trunk liner panel.

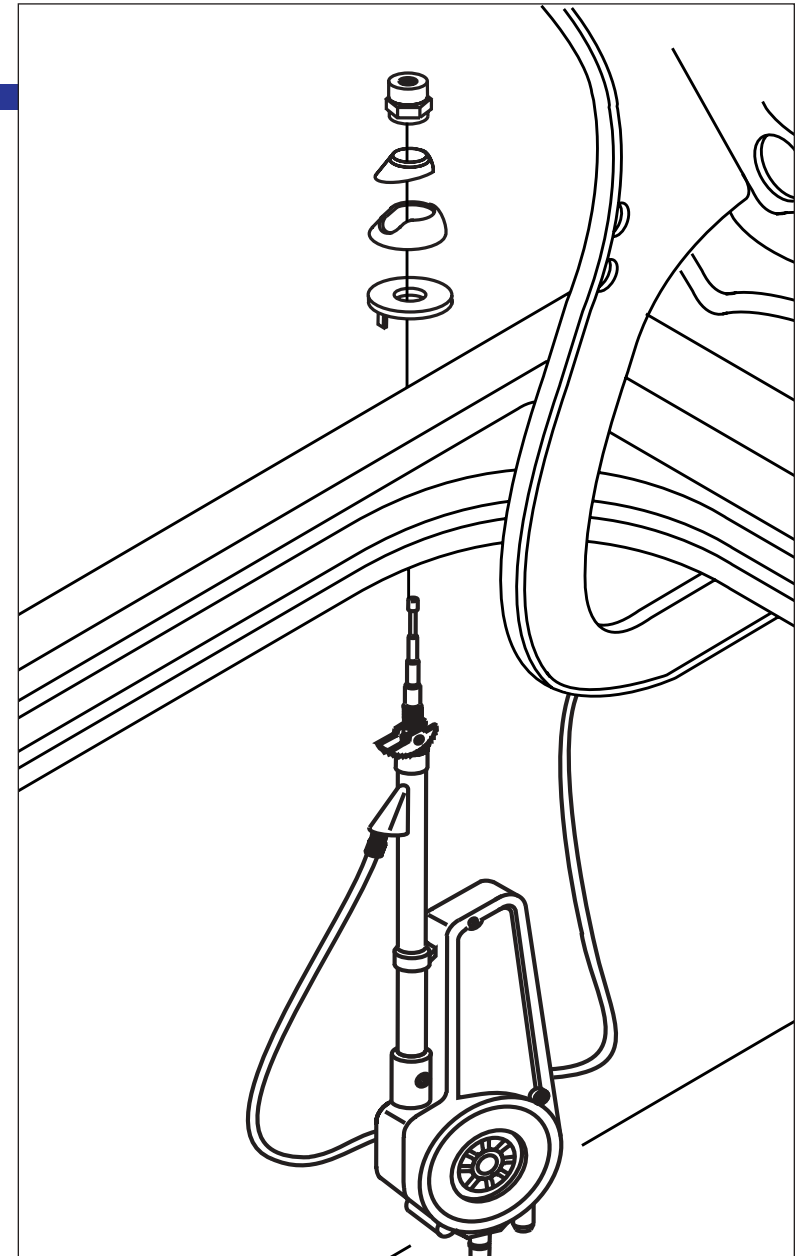
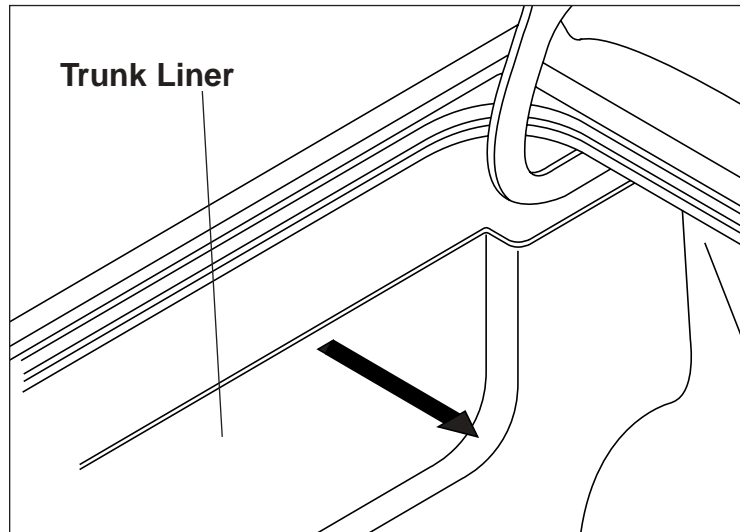

009 0002

# DIN Receiver Installation

1. Slide **DIN sleeve** fully into dash opening. Secure by bending the tabs (see inset).
2. Hold receiver near dash opening. Connect receiver wiring harness to vehicle harness. Plug antenna lead into receiver.
3. Slide receiver fully into sleeve. Test operation.

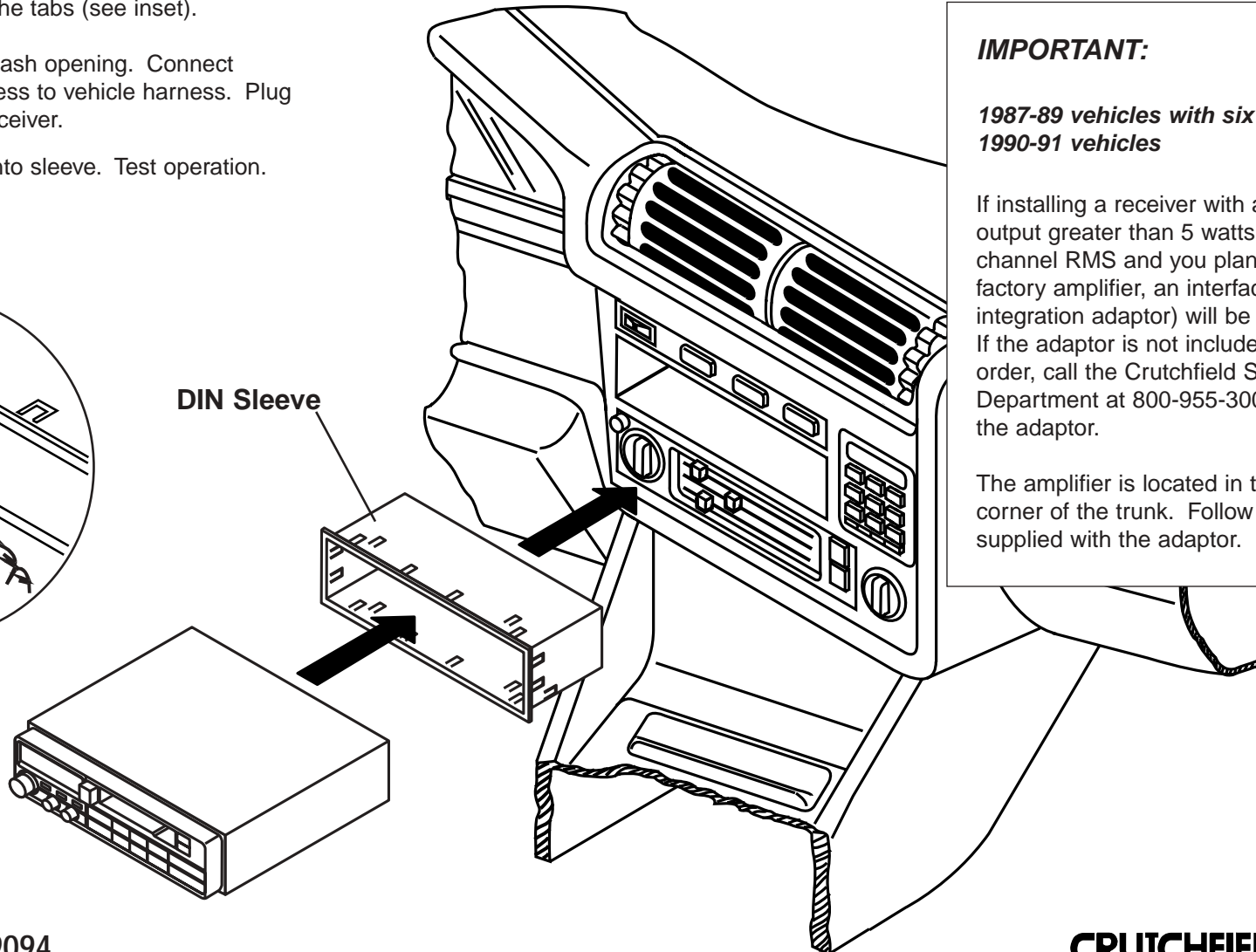
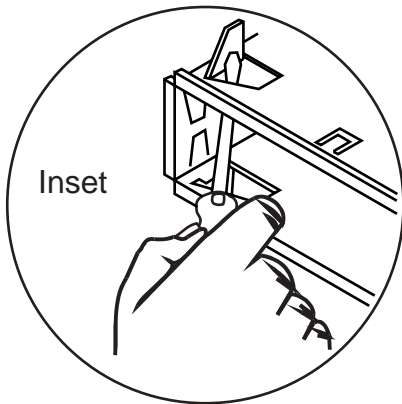

## NOTES:

### *Please read first*

- *Inspect factory receiver harness connector in vehicle. Ensure that the wiring adaptor received from Crutchfield plugs into the vehicle's connector. If the connector is missing or incorrect, please call our Technical Service Department at 1-800-955-9094.*

### **IMPORTANT:**

**1987-89 vehicles with six speakers  
1990-91 vehicles**

If installing a receiver with a power output greater than 5 watts per channel RMS and you plan to use the factory amplifier, an interface (oem integration adaptor) will be necessary. If the adaptor is not included in your order, call the Crutchfield Sales Department at 800-955-3000 to order the adaptor.

The amplifier is located in the left front corner of the trunk. Follow instructions supplied with the adaptor.



1-800-955-9094  
Technical Service

**CRUTCHFIELD®**

Copyright 2005 Crutchfield Corporation

009 0002

# Shaft Receiver Installation

## NOTES:

### *Please read first*

- *Inspect factory receiver harness connector in vehicle. Ensure that the wiring adaptor received from Crutchfield plugs into the vehicle's connector. If the connector is missing or incorrect, please call our Technical Service Department at 1-800-955-9094.*

### **IMPORTANT:**

**1987-89 vehicles with six speakers**  
**1990-91 vehicles**

If installing a receiver with a power output greater than 5 watts per channel RMS, and you plan to use the factory amplifier, an interface (oem integration adaptor) will be needed. If the adaptor is not included in your order, call the Crutchfield Sales Department at 800-955-3000 to order the adaptor.

The amplifier is located in the left front corner of the trunk. Follow instructions supplied with the adaptor.

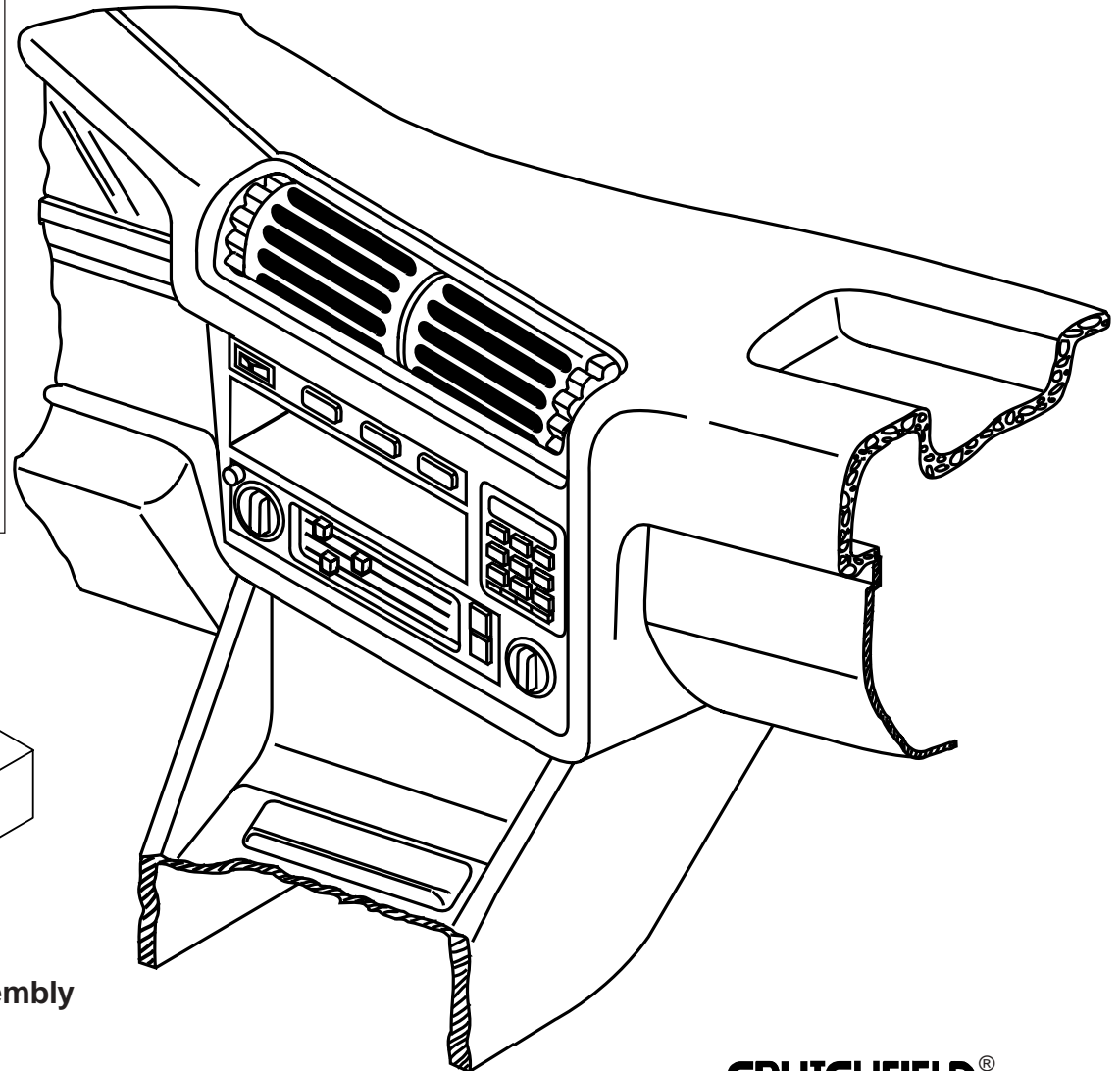

1. Assemble receiver following instructions supplied with the installation kit.
2. Hold **receiver assembly** near dash opening. Connect receiver wiring harness to vehicle harness. Plug antenna lead into receiver.
3. Slide receiver assembly into dash opening until it locks into place.
4. Test operation.

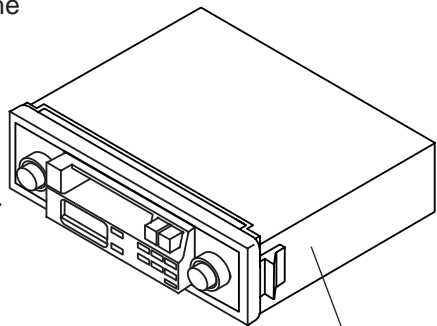

**Receiver Assembly**



**1-800-955-9094**  
Technical Service

**CRUTCHFIELD®**

Copyright 2005 Crutchfield Corporation

009 0002

# Front Speakers -- Kick Panels

## NOTES:

**Please read first**

- Instructions show factory size speakers only. Cutting, fabricating, or speaker adaptor brackets (not shown) will be required for other speaker sizes.

1. Remove one (1) phillips screw securing **kick panel/grille**. (This screw is also one of the screws securing speaker.)
2. Pull **moulding** around door away from edge of kick panel/grille and remove kick panel/grille.
3. Remove three (3) remaining screws securing speaker. Pull out speaker and disconnect spade connectors from speaker to remove.
4. Connect speaker wires to replacement speaker making sure that polarity is correct.
5. Secure replacement speaker in the same manner as factory speaker.
6. Test speaker operation and reinstall kick panel/grille.

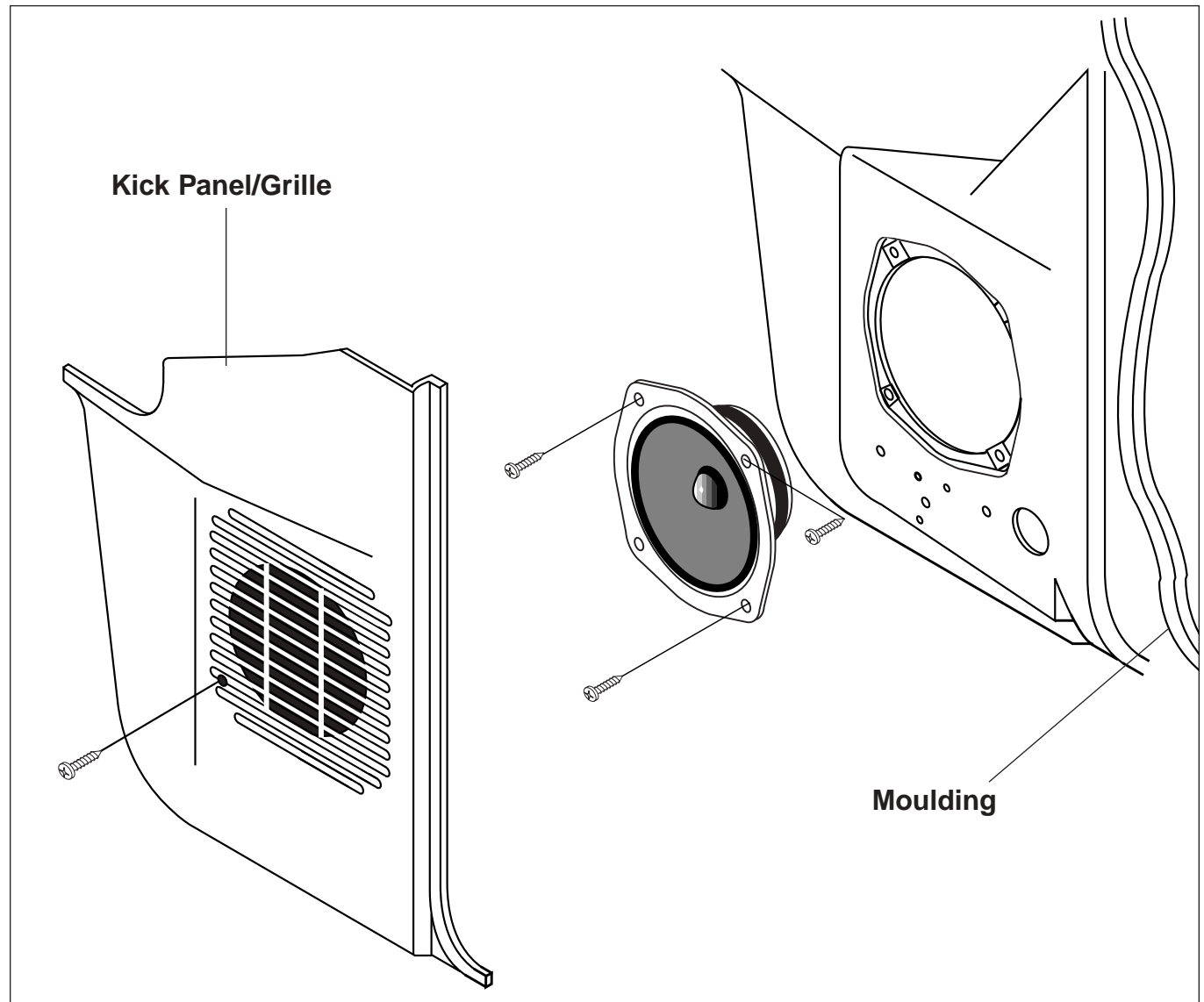

 1-800-955-9094  
Technical Service

**CRUTCHFIELD**<sup>®</sup>

Copyright 2005 Crutchfield Corporation

009 0002

# Rear Speakers -- Sedan

## NOTES:

**Please read first**

- Instructions show factory size speakers only. Cutting, fabricating, or speaker adaptor brackets (not shown) will be required for other speaker sizes.

### Style A

1. Pry off **speaker grille** using a panel tool.
2. Remove four screws securing speaker to **enclosure**. Lift out speaker and disconnect wires to remove.
3. Connect speaker wiring to replacement speaker making sure polarity is correct.
4. Secure replacement speaker to enclosure using screws previously removed.
5. Test speaker operation and reinstall grille.

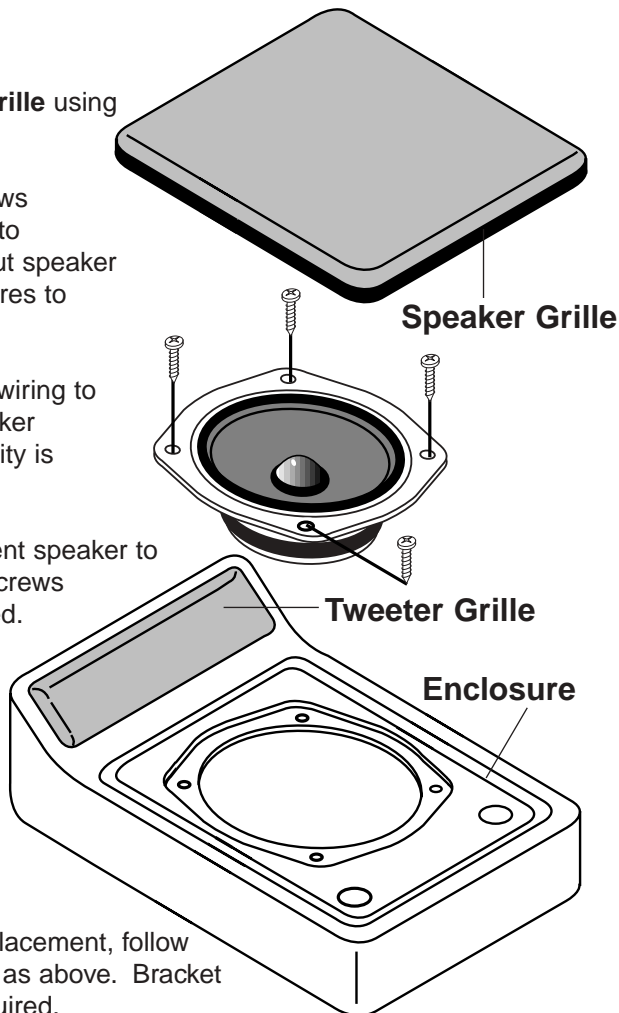

**Note:** For tweeter replacement, follow the same instructions as above. Bracket fabrication will be required.

### Style B

1. Remove four screws securing **speaker grille** and speaker to **rear deck**. Lift off grille and pull out speaker. Disconnect wires and remove.
2. Connect speaker wiring to replacement speaker making sure polarity is correct.
3. Test speaker operation. Secure speaker and grille to deck using screws previously removed.

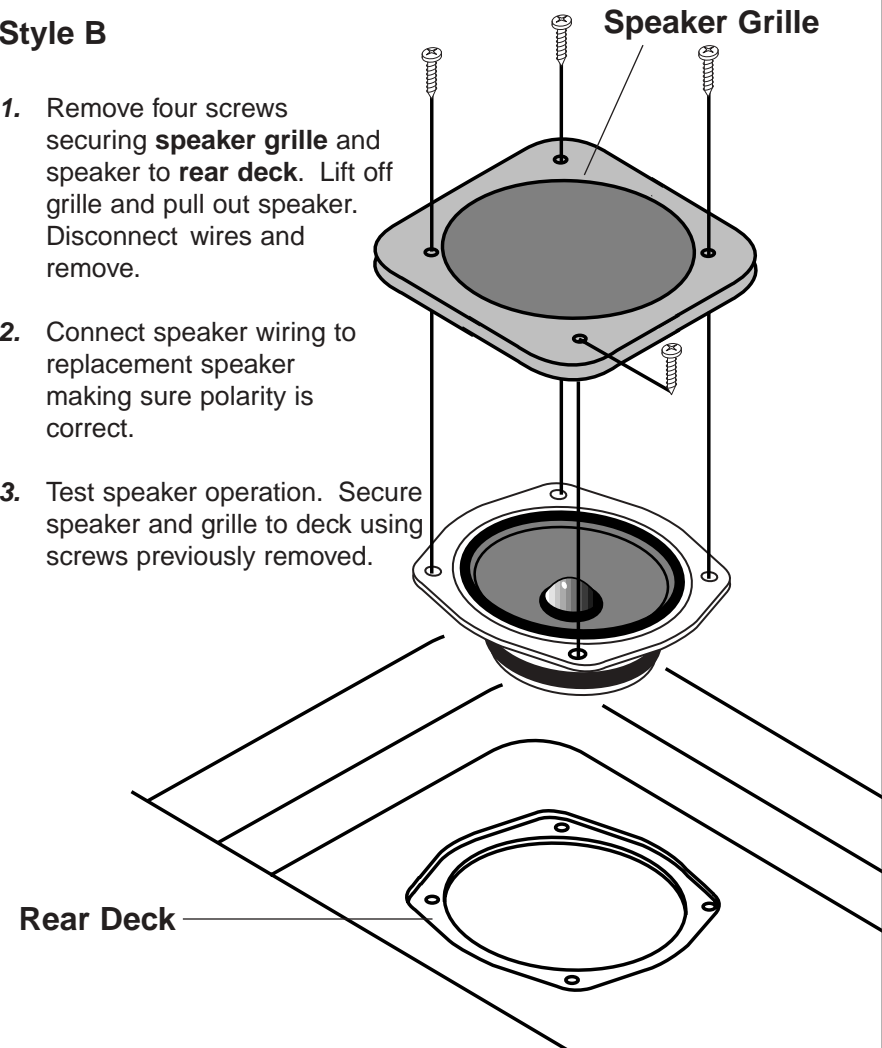

009 0002

# Rear Speakers -- Convertible

## NOTES:

**Please read first**

- Instructions show factory size speakers only. Cutting, fabricating, or speaker adaptor brackets (not shown) will be required for other speaker sizes.

1. Pry out **grille panel** along top edge. Slide upward to remove.

**Note:** *On driver's side, the convertible top release latch must be removed before the grille panel can be removed. To do so, pull outward on front edge of trim ring and slide toward rear of vehicle and remove (see Inset).*

2. Remove four (4) phillips screws securing speaker to **side panel**.
3. Tilt speaker and pull speaker out of cavity. Disconnect speaker wiring and remove speaker.
4. Connect speaker wiring making sure that polarity is correct.
5. Secure speaker to panel with screws removed from factory speaker.
6. Test operation and reinstall grille panel.

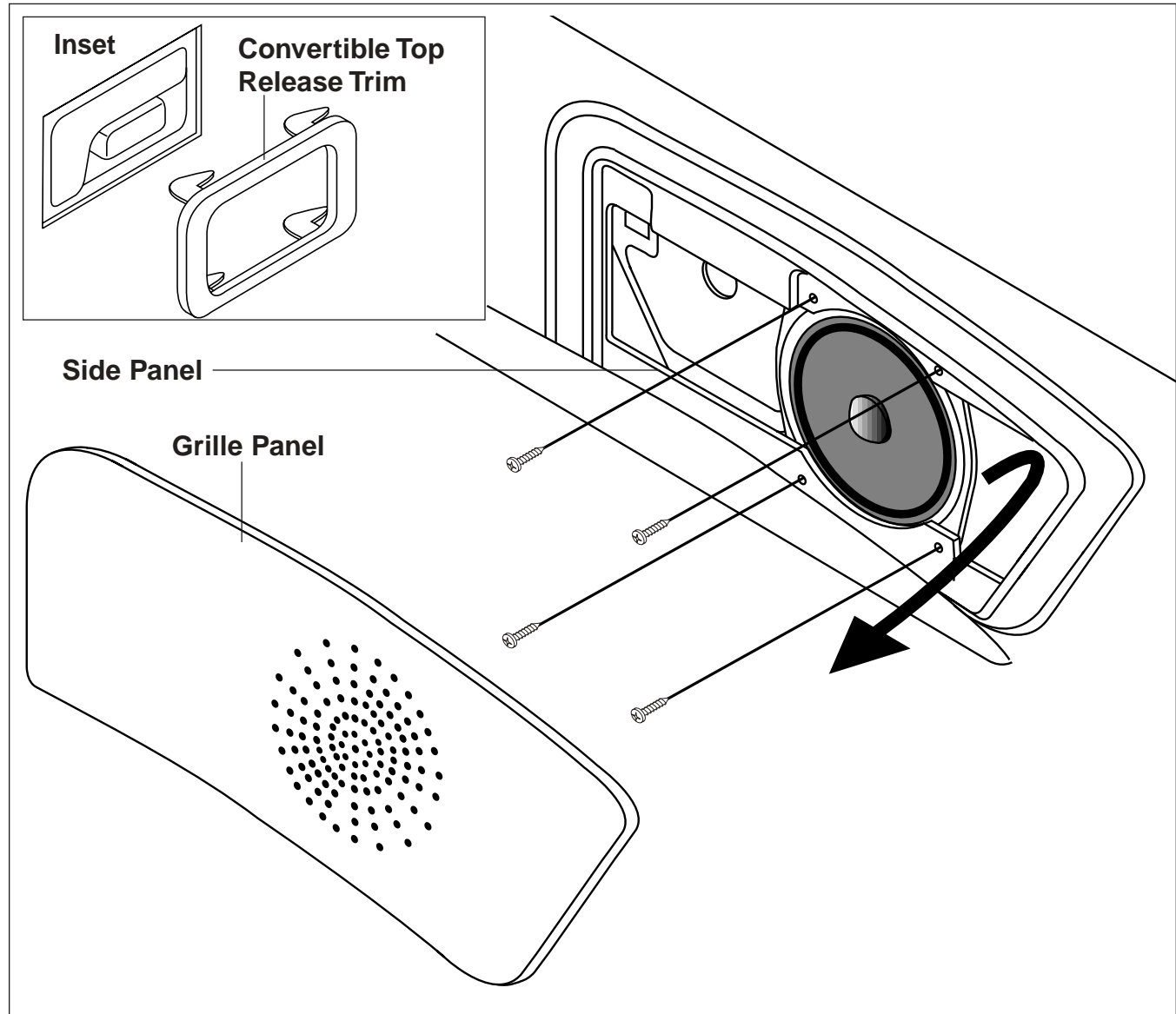

1-800-955-9094  
Technical Service

**CRUTCHFIELD**®

Copyright 2005 Crutchfield Corporation