

REVISIONS			
REV.	DESCRIPTION	DATE	APPROVED

ITEM	NO / MTRL	DESCRIPTION	QTY
1	6061-T6 Al.	CENTER	2
2	UHMW	SPRING PAD	2
3		Perch	Ref.
4		Spring	Ref.

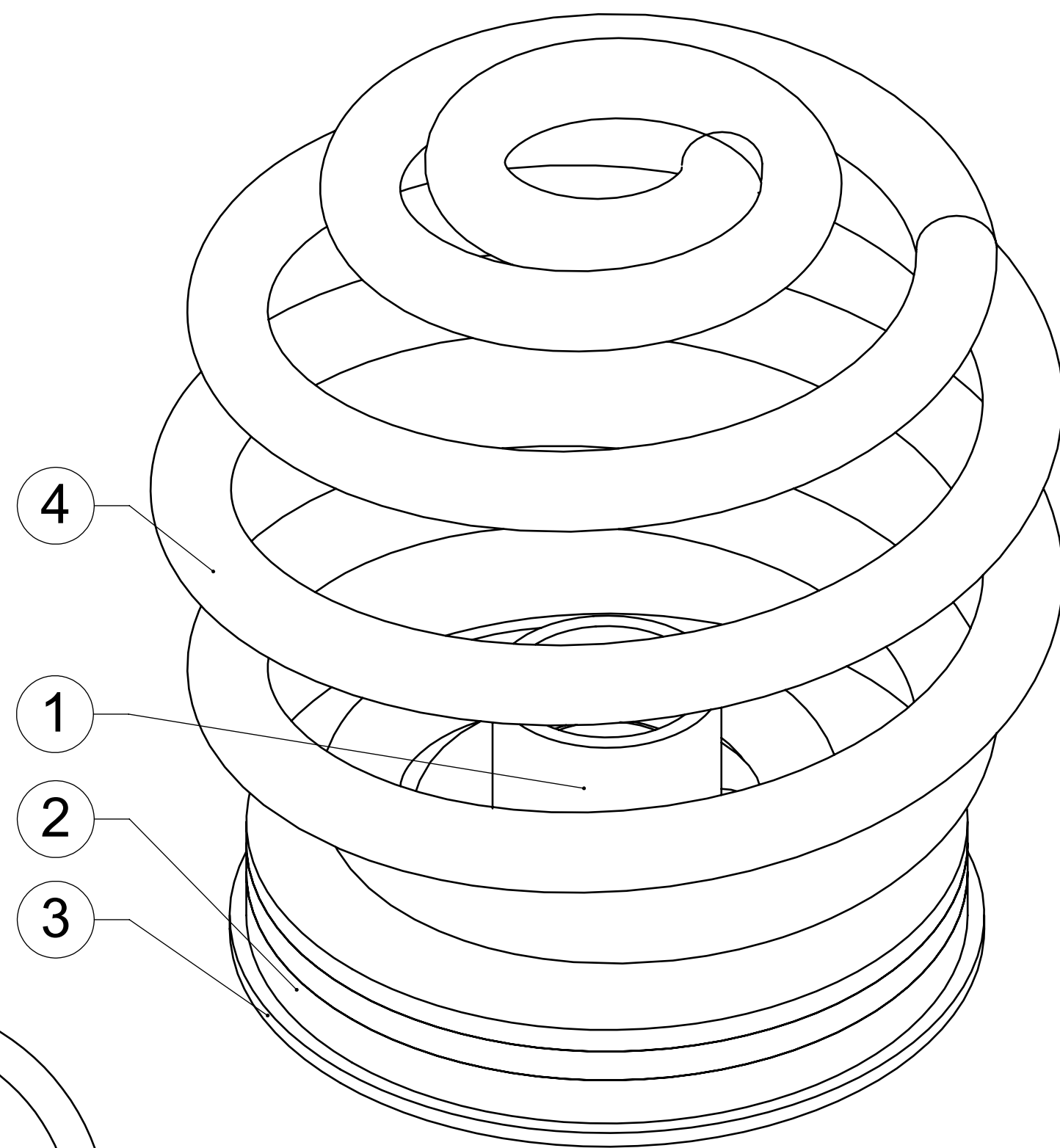

ITEM 1: CENTER
 MATERIAL: 6061-T6 Al.
 QTY: 2

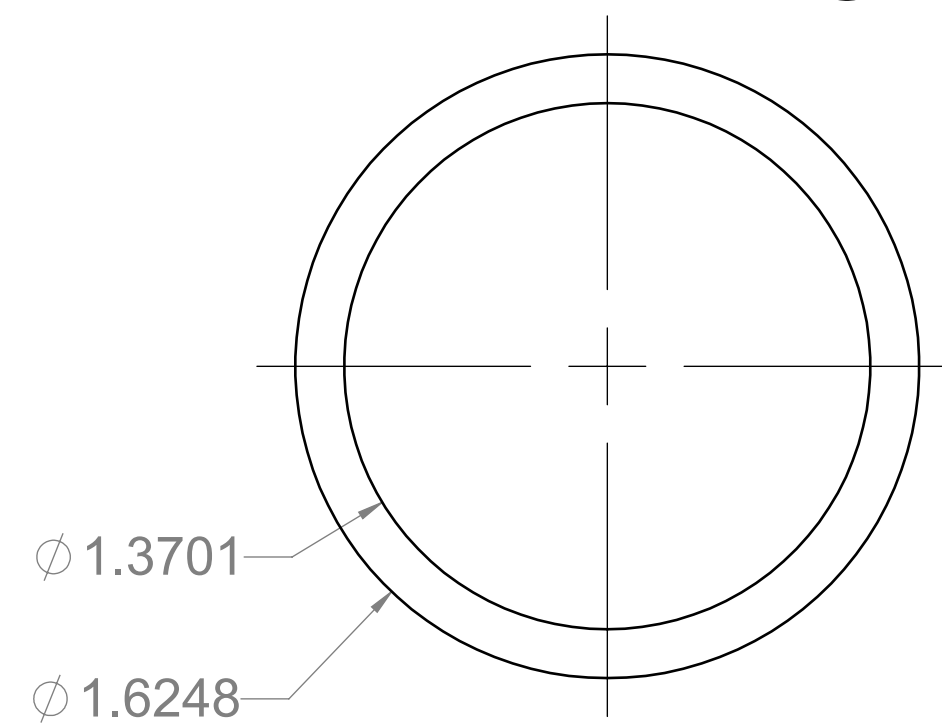

ITEM 2: SPRING PAD
 MATERIAL: UHMW
 QTY: 2 EACH

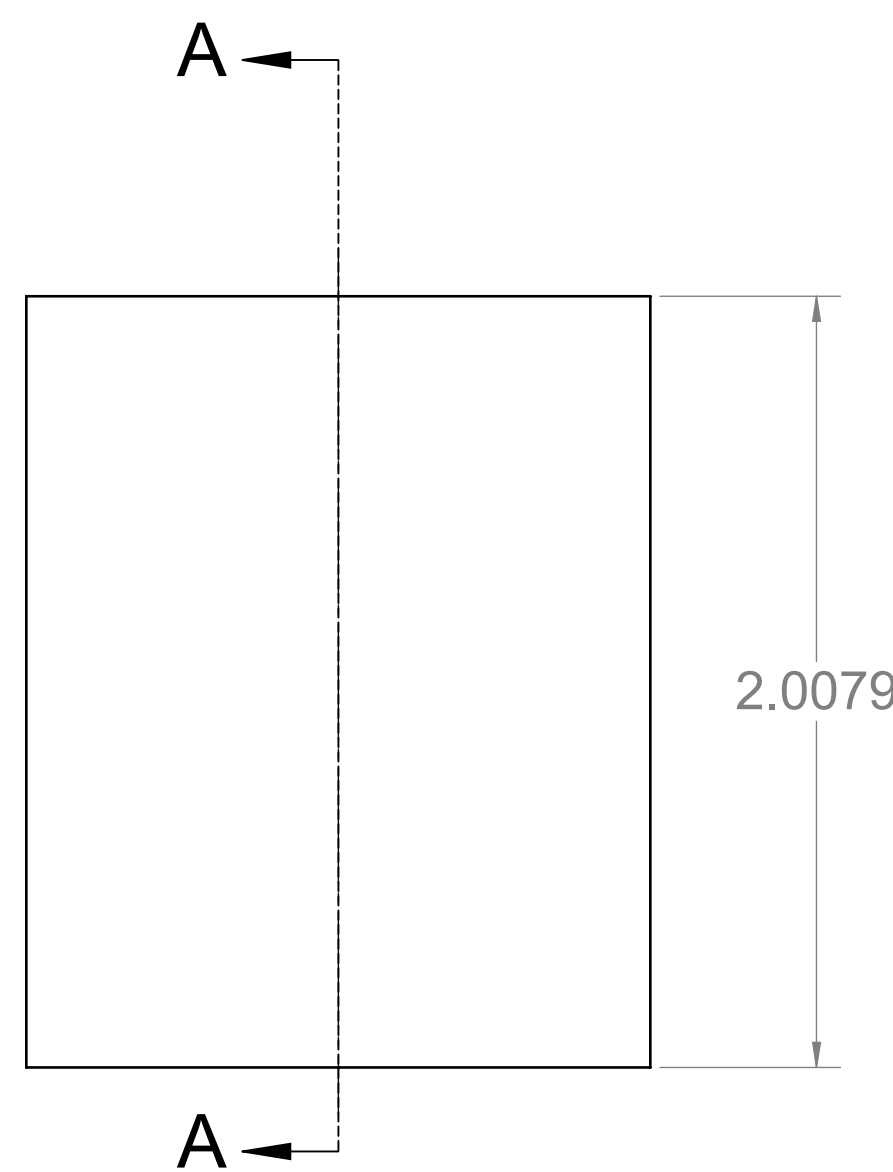
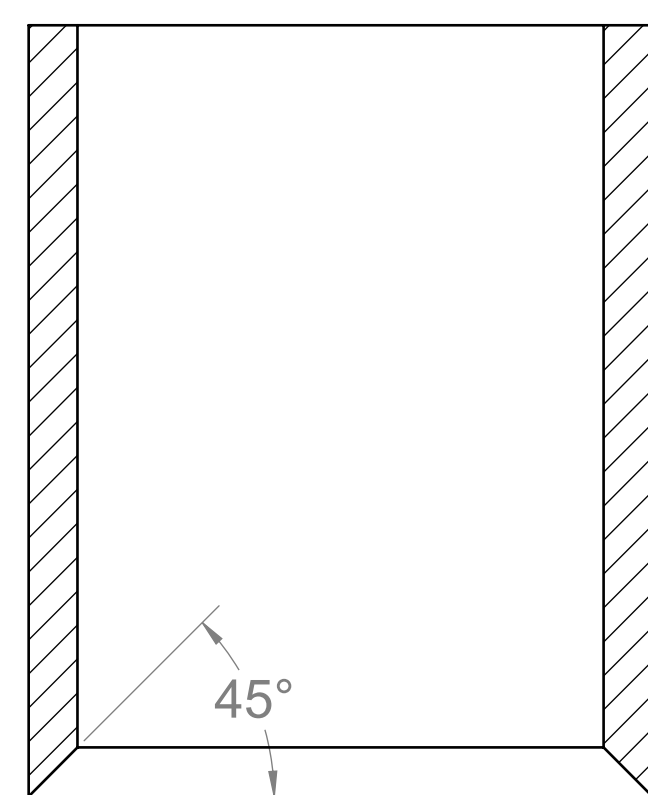
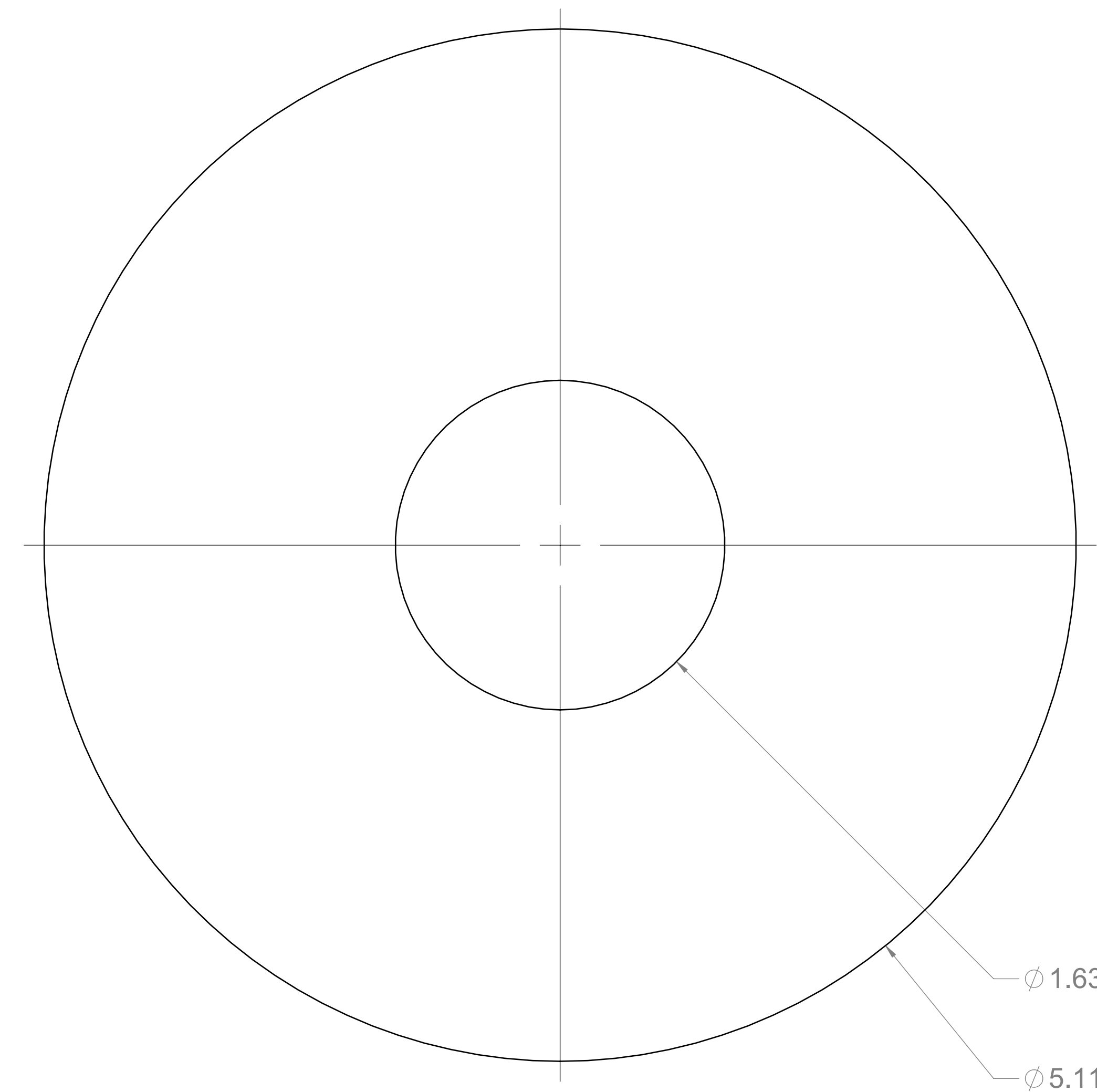

SECTION A-A
 SCALE 2 : 1

NOTES: UNLESS OTHERWISE SPECIFIED

1. REMOVE BURRS AND BREAK ALL SHARP EDGES .02 x 45° CHAMFER OR RADIUS.
2. CLEAN PART WITH SOAP AND WATER.

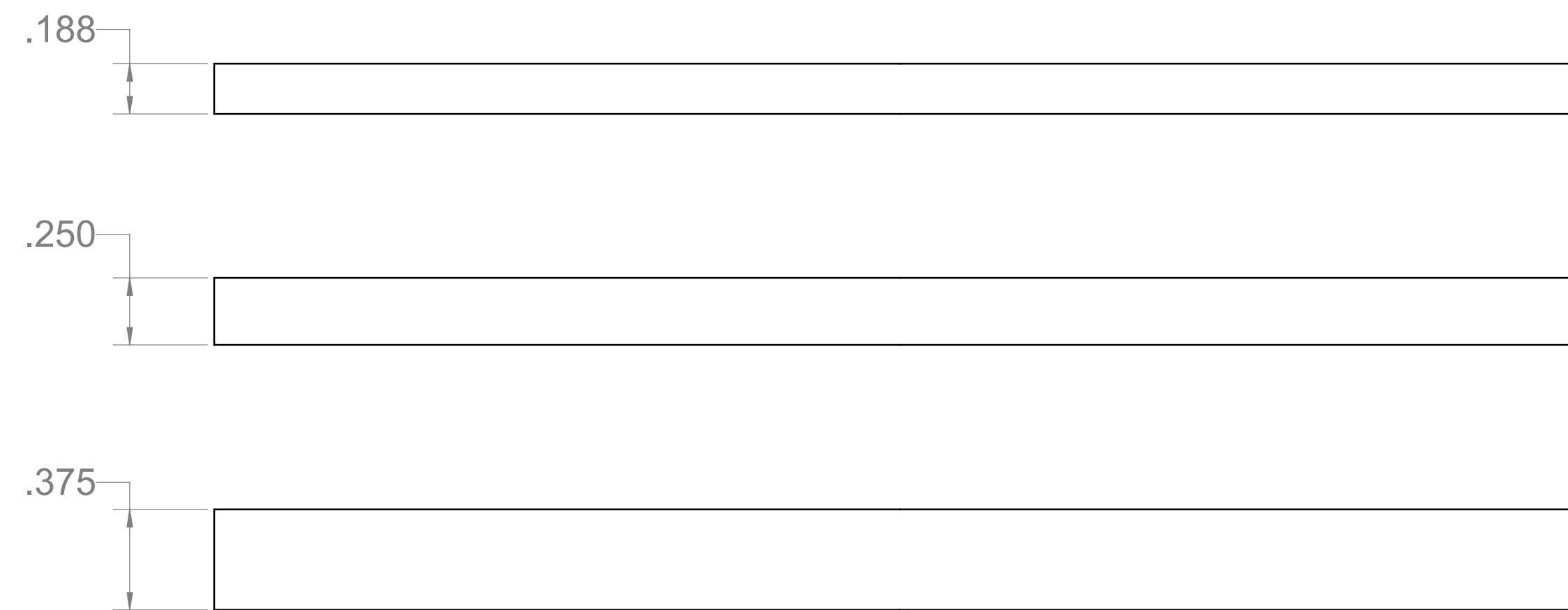

UNLESS OTHERWISE SPECIFIED
 DIMENSIONS ARE IN INCHES.
 TOLERANCES ARE:

.X : ±.03
 .XX : ±.01
 .XXX : ±.005
 ANGLES : ±.25°

MATERIAL: SEE NOTES
 FINISH: SEE NOTES
 DO NOT SCALE DRAWING

CAD GENERATED DRAWING.
 DO NOT MANUALLY UPDATE

APPROVALS	DATE
DRAWN J. Rlj	3/4/2019
CHECKED [CheckedBy]	[ChkDate]

THIRD ANGLE PROJECTION



McGyver's
BMW E30 PARTS
SPRING PAD

SIZE D DWG. NO.: XXX-XX-XXX

SHEET 1 OF 1