

REV	REVISION DESCRIPTION	AUTHORIZATIONS
X	X	DESIGNER: SVS 04/28/2014 CHECKER: --- --- DATASET CHECKER: --- --- APPROVAL: --- ---

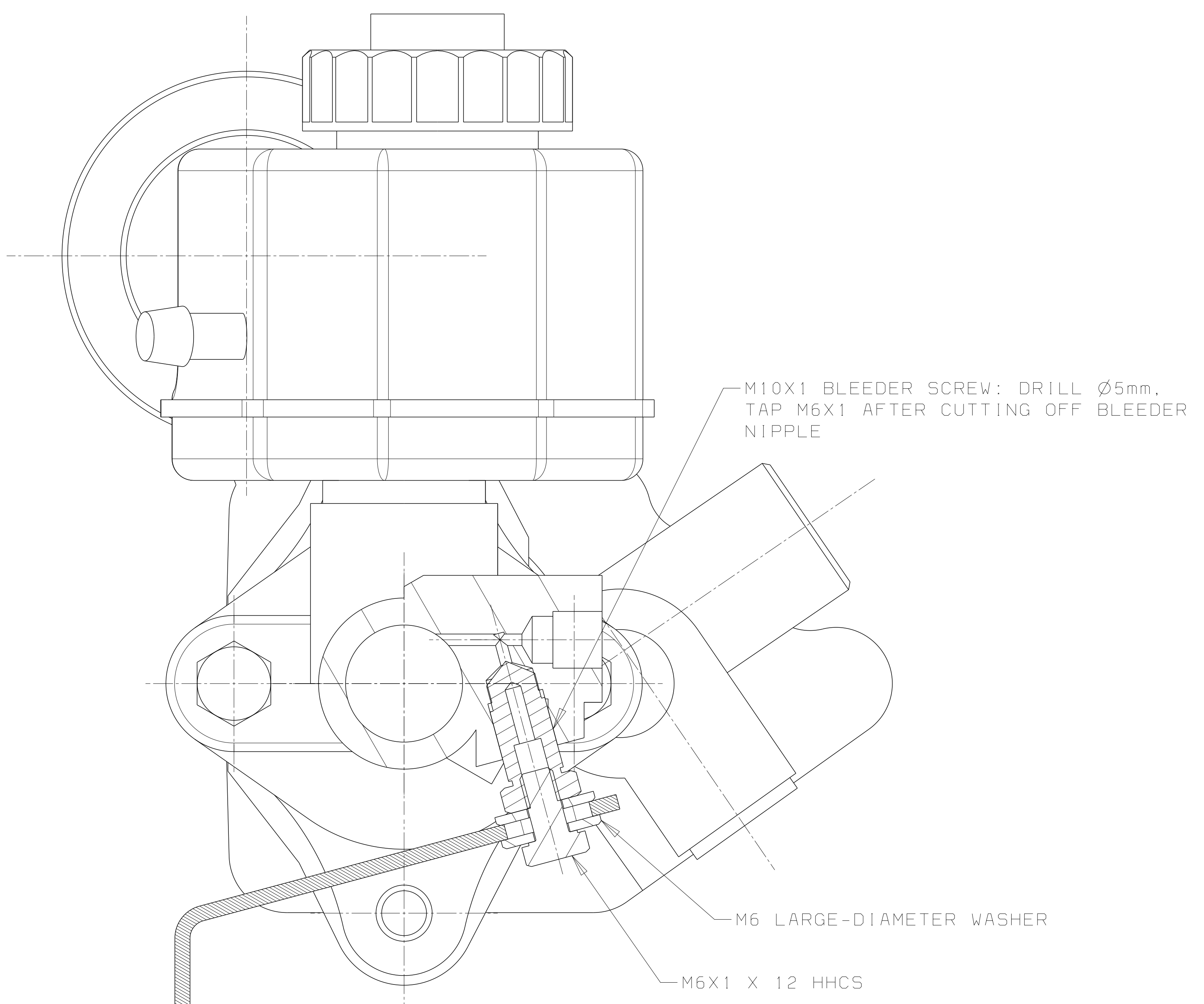

**1H7-1**  
SCALE: 2:1  
ROTATED 90° CCW

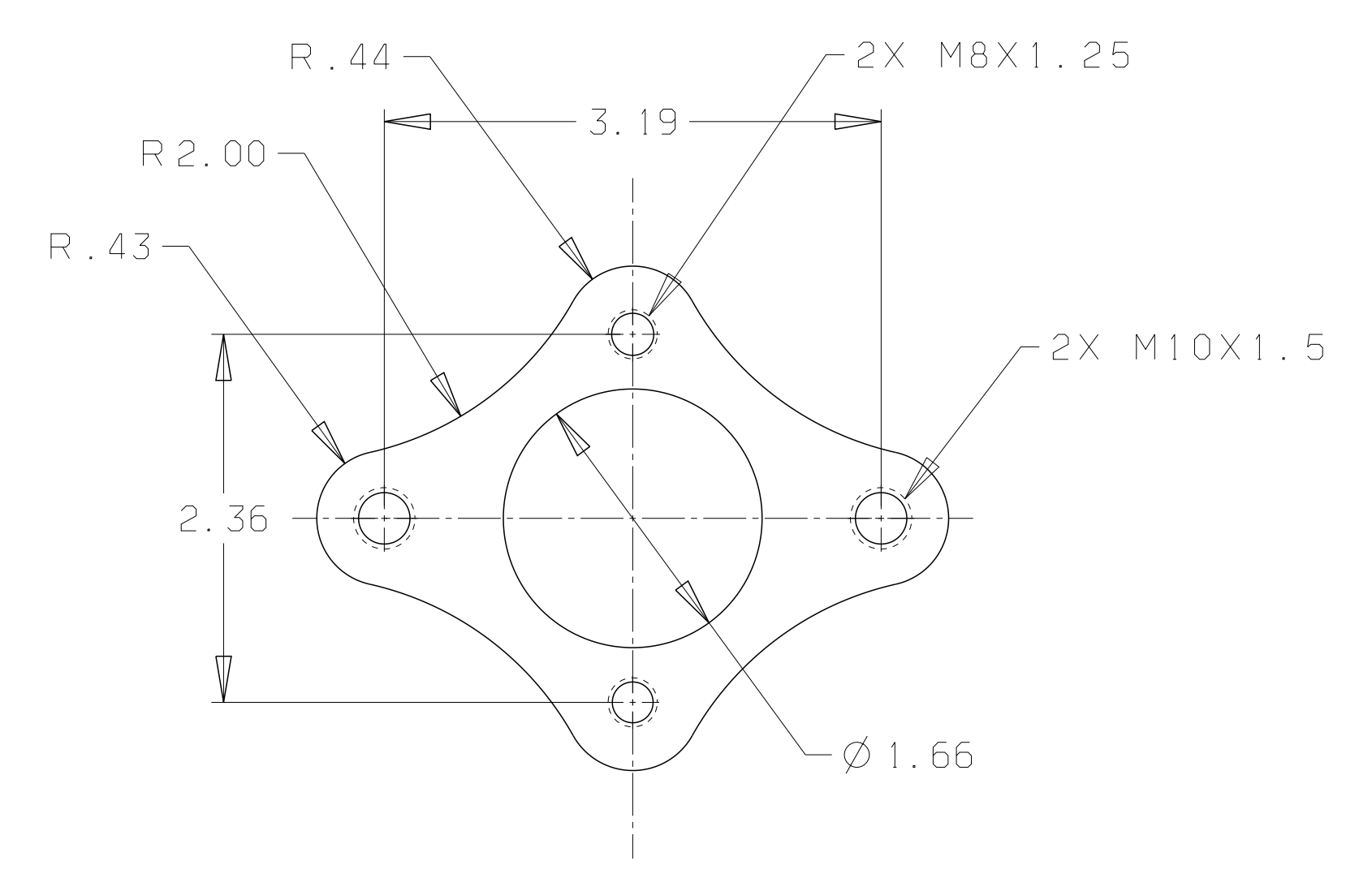

**MC SPACER**  
SCALE: 1:1  
.38 STEEL OR ALUMINUM

**101** VERIFY THIS DIMENSION FOR YOUR SET-UP. DEPTH OF RECESS IN HYDROBOOST ASSY MAY VARY, OR IF A DIFFERENT BENDIX HB IS USED, THERE SHOULD BE FREE PLAY BETWEEN HB AND BMW MASTER CYL. FREE-PLAY MUST BE PRESENT FOR BRAKES TO FUNCTION PROPERLY!

**102** USE A STANDARD HACK-SAW TO CAREFULLY CUT A GROOVE ALL AROUND THE SHAFT. TWO OR THREE STROKES, THEN ROTATE SHAFT A LITTLE, THEN MORE STROKES. REPEAT UNTIL DONE ALL AROUND. WRAP SHAFT WITH BLUE TAPE AS A GUIDE BEFORE CUTTING GROOVE. FINISH WITH A SQUARE-EDGE JEWELERS FILE IF NEEDED. GROOVE TO BE ABOUT .015DEEP BY .03 WIDE.

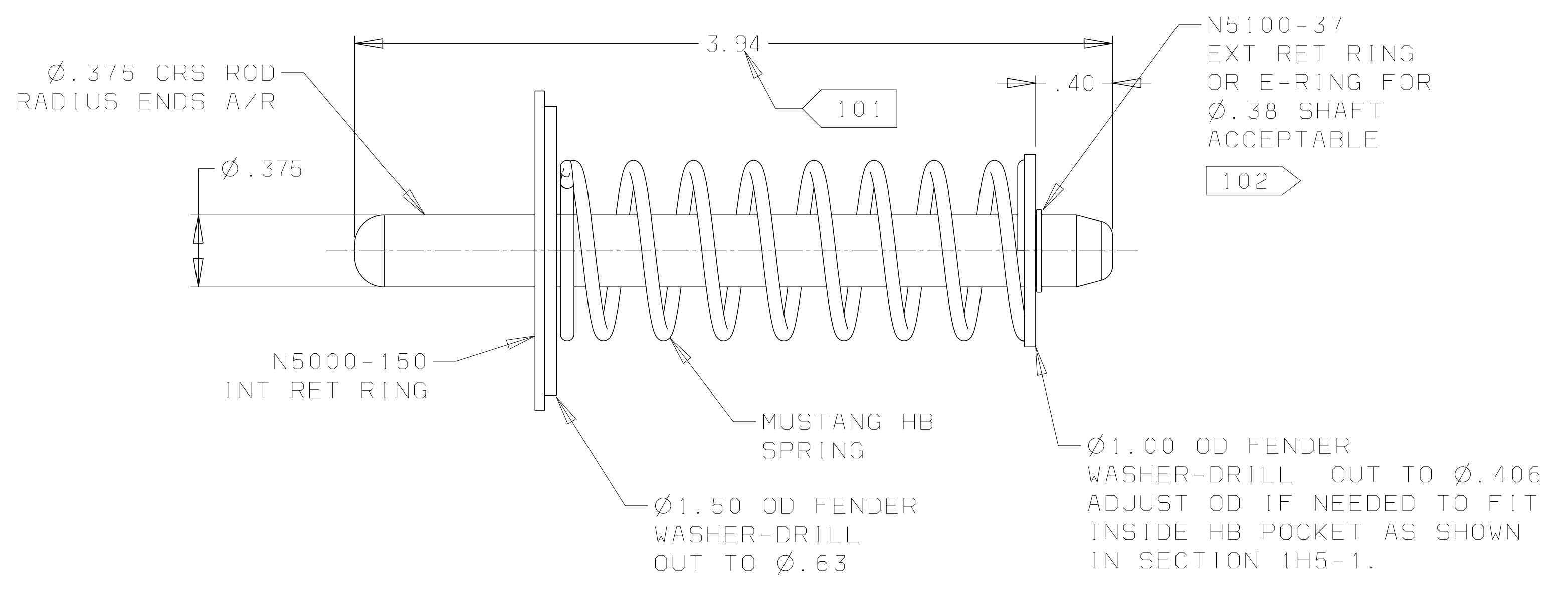

**INTERMEDIATE PUSHROD ASSY**  
Scale: 2:1

MAKE IF YOU DO NOT HAVE ONE. OTHERWISE MODIFY YOUR EXISTING PART BY SHORTENING AS SHOWN.

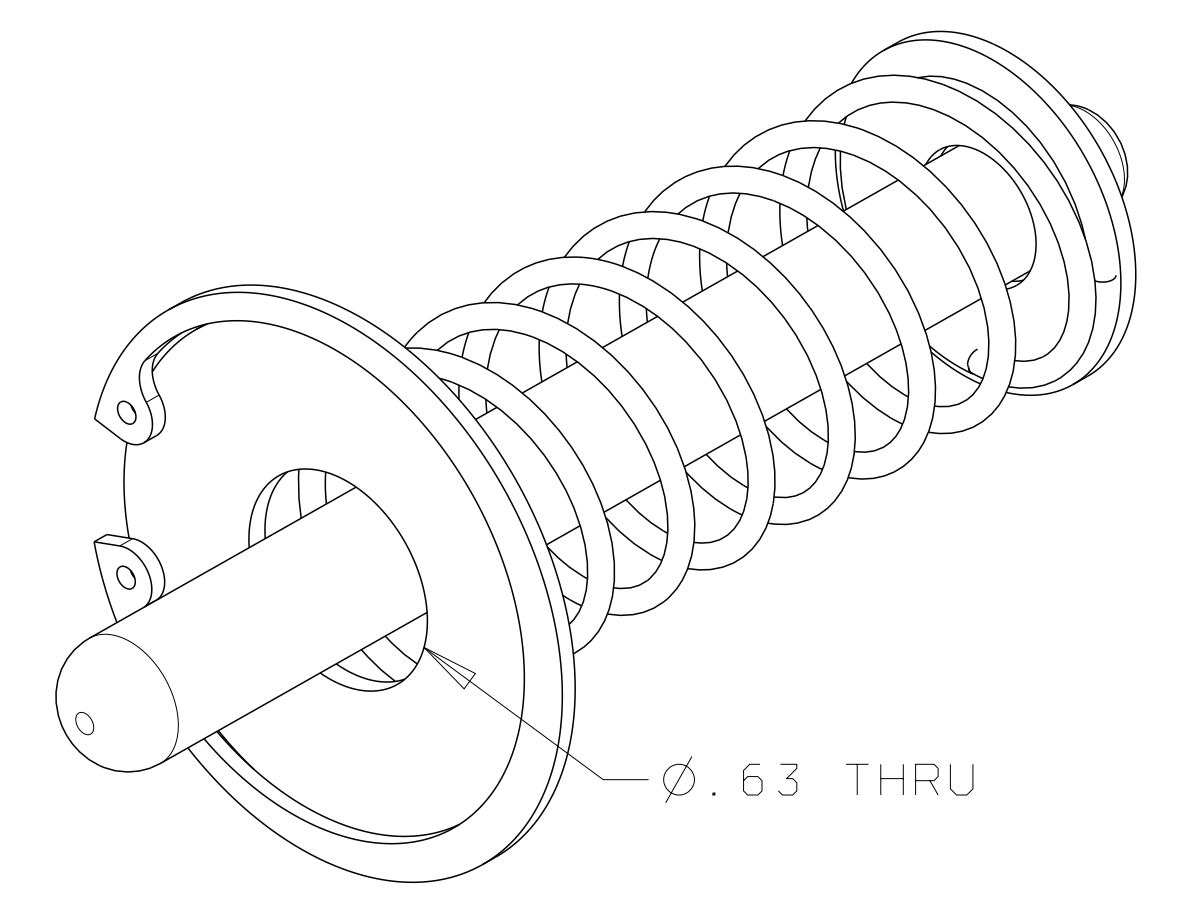

Isometric view[2]  
Scale: 2:1

**BY YOUR USE OF THIS DESIGN, IT IS YOUR RESPONSIBILITY FOR ANY LOSS OR DAMAGE TO PERSONS OR PROPERTY. WE PROVIDE THIS DESIGN FREE OF CHARGE FOR YOUR PERSONAL USE, AND THIS DESIGN MAY NOT BE USED FOR COMMERCIAL PURPOSES BY YOU OR YOUR ASSIGNS.**

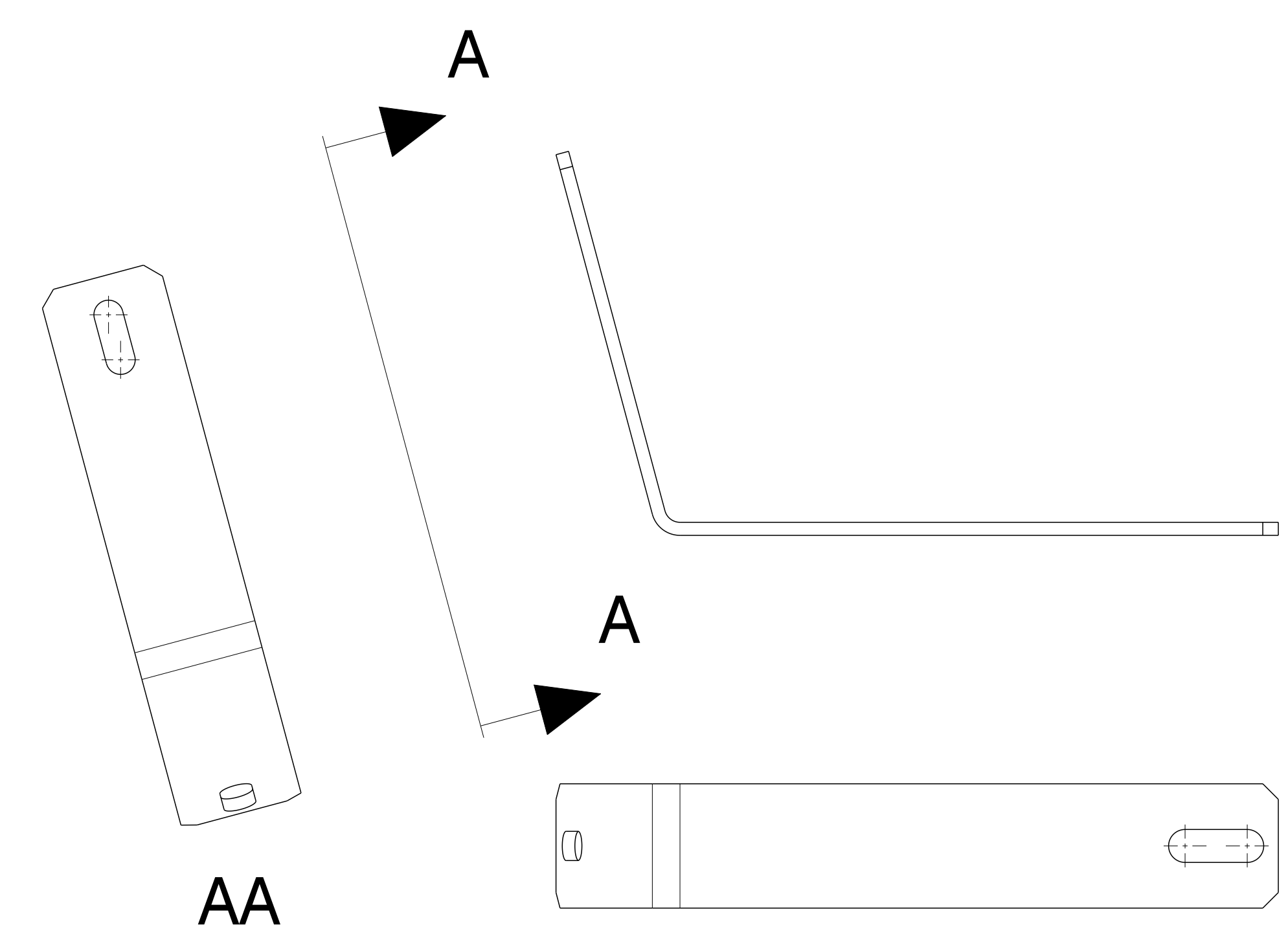

**MC SUPPORT STRAP**

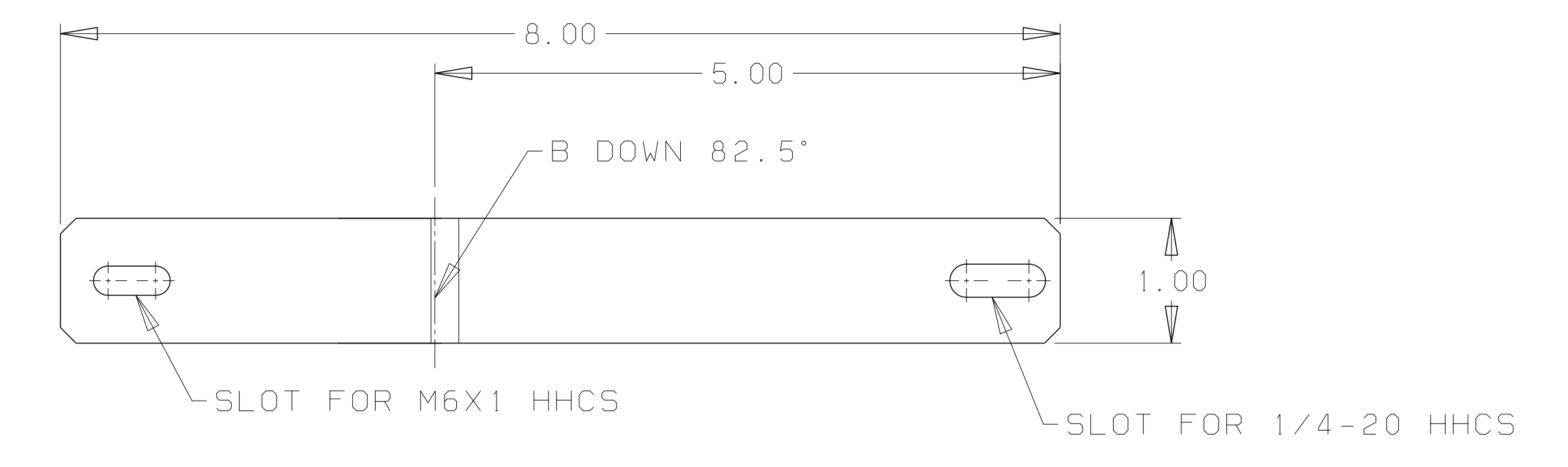

**FLAT PATTERN**

DETAIL NO	QUANTITY	NAME OF DETAIL	ZONE	MATERIAL	STOCK SIZE
EXCEPT AS NOTED		SCALE		ALL DIMENSIONS IN INCHES	
TOLERANCES DECIMAL		63 ✓		FLOOR AREA APPROX WT	
.X = ±.03				---	
.XX = ±.010					
.XXX = ±.005					
ANGULAR = ±.5°					
REVISIONS	DATE	DESIGNED	NAME	DATE	
XXX/XX/XX		G VAN SWERINGEN		04/28/14	
		S VAN SWERINGEN		04/28/14	
		CHECKED	XXXX	XX/XX/XX	
		DRAWN	XXXX	XX/XX/XX	
		CHECKED	XXXX	XX/XX/XX	
FINISH		E NEW			
COLOR OR PROTECTIVE		SHT SIZE		REV	
				DVG NO	
				SHT NO	
E30-LS1 BMW E30 MC 1999 MUSTANG HB					